

PART NUMBER: CPE-352

DESCRIPTION: piezo audio indicators

SPECIFICATONS

operating frequency	2.8 ± 0.5 KHz	
operating voltage range	3 ~ 28 V DC	
current consumption	10 mA max.	at 12 V DC
sound pressure level	89 db min.	at 30 cm/12 V DC
rated voltage	12 V DC	
tone	continuous	
operating temperature	-30 ~ +85° C	
storage temperature	-40 ~ +95° C	
dimensions	Ø42.0 x H14.0 mm	
weight	12.0 g max.	
material	ABS UL-94 1/16" high heat (black)	
terminal	pin type (Au plating)	
RoHS	yes	

APPEARANCE DRAWING

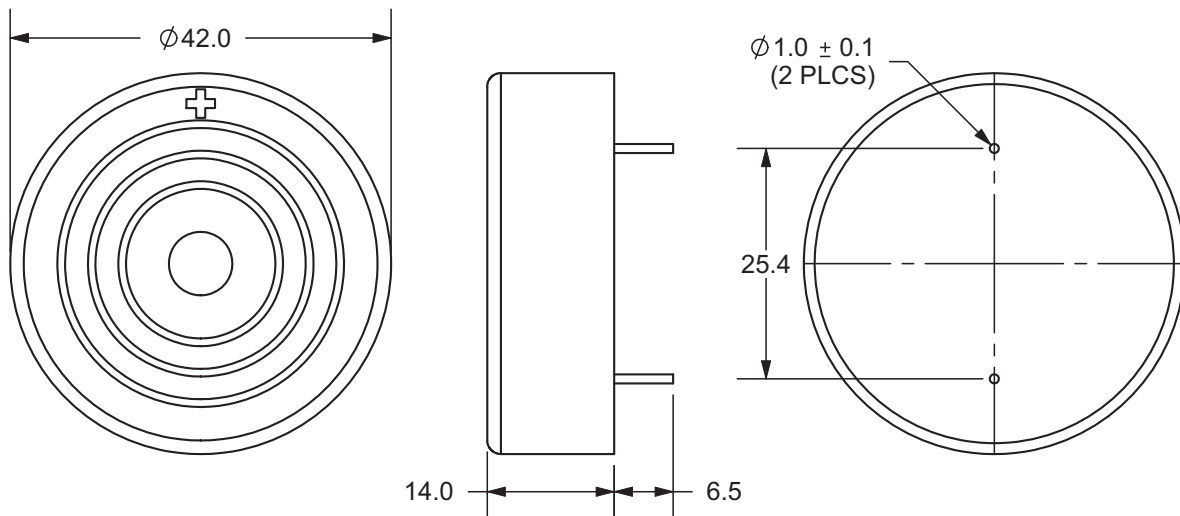
 tolerance: ±0.5
 units: mm

PART NUMBER: CPE-352

DESCRIPTION: piezo audio indicators

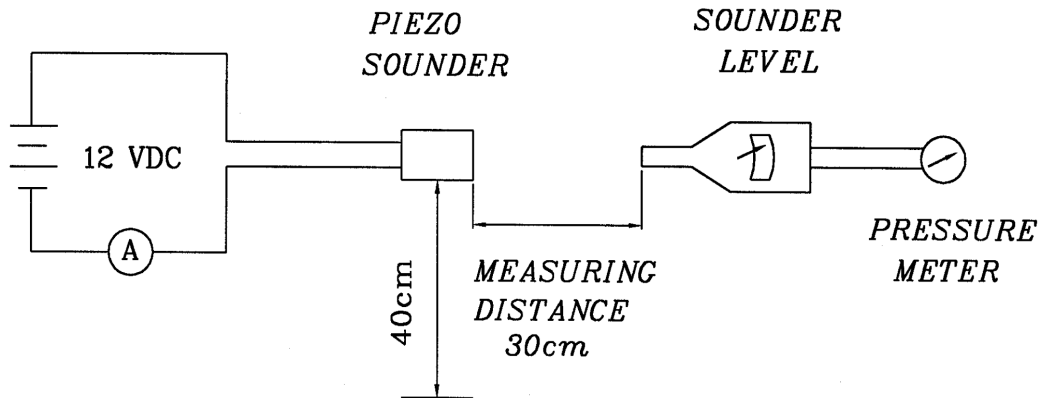
MEASUREMENT METHOD

S.P.L. Measuring Circuit

Mic: RION S.P.L. meter UC30 or equivalent

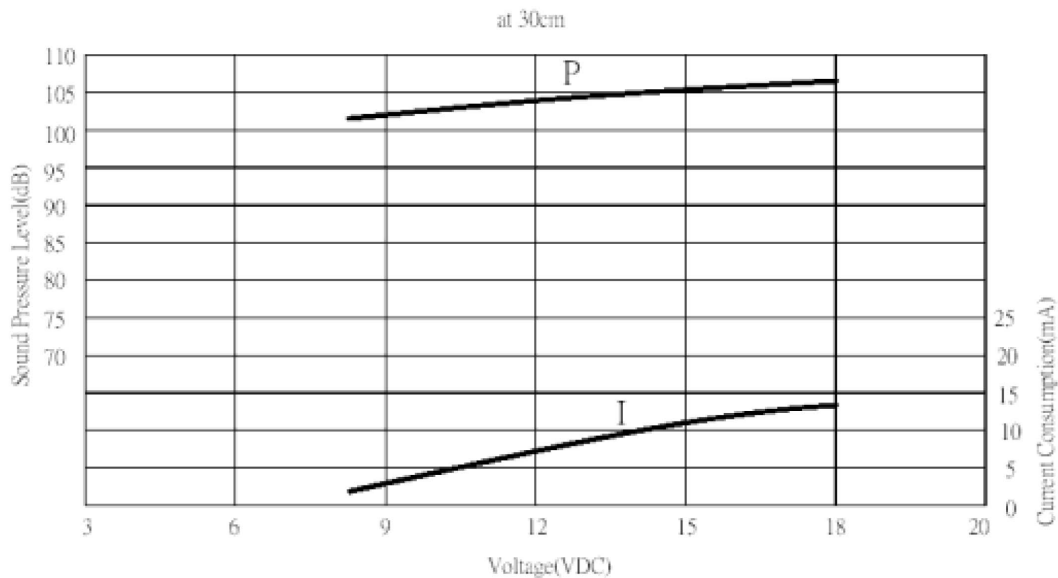
CURRENT CONSUMPTION/SOUND PRESSURE LEVEL

PART NUMBER: CPE-352

DESCRIPTION: piezo audio indicators

MECHANICAL CHARACTERISTICS

item	test condition	evaluation standard
solderability	Lead terminals are immersed in rosin for 5 seconds and then immersed in solder bath of $270 \pm 5^{\circ}\text{C}$ for 3 ± 1 seconds.	90% min. of the lead terminals will be wet with solder (except the edge of the terminal).
soldering heat resistance	Lead terminals are immersed up to 1.5mm from buzzer's body in solder bath of $300 \pm 5^{\circ}\text{C}$ for 3 ± 0.5 seconds or $260 \pm 5^{\circ}\text{C}$ for 10 ± 1 seconds.	No interference in operation.
terminal strength pulling	For 10 seconds, the force of 300g is applied to each terminal in axial direction.	No damage or cutting off.
vibration	The buzzer shall be measured after applying a vibration amplitude of 1.5 mm with 10 to 55 Hz band of vibration frequency to each of the 3 perpendicular directions for 2 hours.	The value of oscillation frequency/current consumption should be $\pm 10\%$ of the initial measurements. The SPL should be within $\pm 10\text{dB}$ compared with the initial measurement.
drop test	The part will be dropped from a height of 75 cm onto a 40 mm thick wooden board 3 times in 3 axes (X, Y, Z) for a total of 9 drops.	

ENVIRONMENT TEST

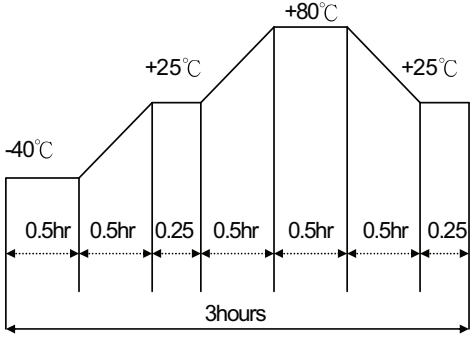
item	test condition	evaluation standard
high temp. test	After being placed in a chamber at $+95^{\circ}\text{C}$ for 240 hours.	The buzzer will be measured after being placed at $+25^{\circ}\text{C}$ for 4 hours. The value of the oscillation frequency/current consumption should be $\pm 10\%$ compared to the initial measurements. The SPL should be within $\pm 10\text{dB}$ compared to the initial measurements.
low temp. test	After being placed in a chamber at -40°C for 240 hours.	
humidity test	After being placed in a chamber at $+40^{\circ}\text{C}$ and $90 \pm 5\%$ relative humidity for 240 hours.	
temp. cycle test	The part shall be subjected to 5 cycles. One cycle will consist of: 	

PART NUMBER: CPE-352**DESCRIPTION:** piezo audio indicators

RELIABILITY TEST

item	test condition	evaluation standard
operating (life test)	1. Continuous life test: The part will be subjected to 48 hours of continuous operation at +70°C with rated voltage applied. 2. Intermittent life test: A duty cycle of 1 minute on, 1 minutes off, a minimum of 5,000 times at room temp (+25 ±2°C) with rated voltage applied.	The buzzer will be measured after being placed at +25°C for 4 hours. The value of the oscillation frequency/current consumption should be ±10% compared to the initial measurements. The SPL should be within ±10dB compared to the initial measurements.

TEST CONDITIONS

standard test condition	a) temperature: +5 ~ +35°C	b) humidity: 45 - 85%	c) pressure: 860-1060 mbar
judgement test condition	a) temperature: +25 ±2°C	b) humidity: 60 - 70%	c) pressure: 860-1060 mbar

PART NUMBER: CPE-352

DESCRIPTION: piezo audio indicators

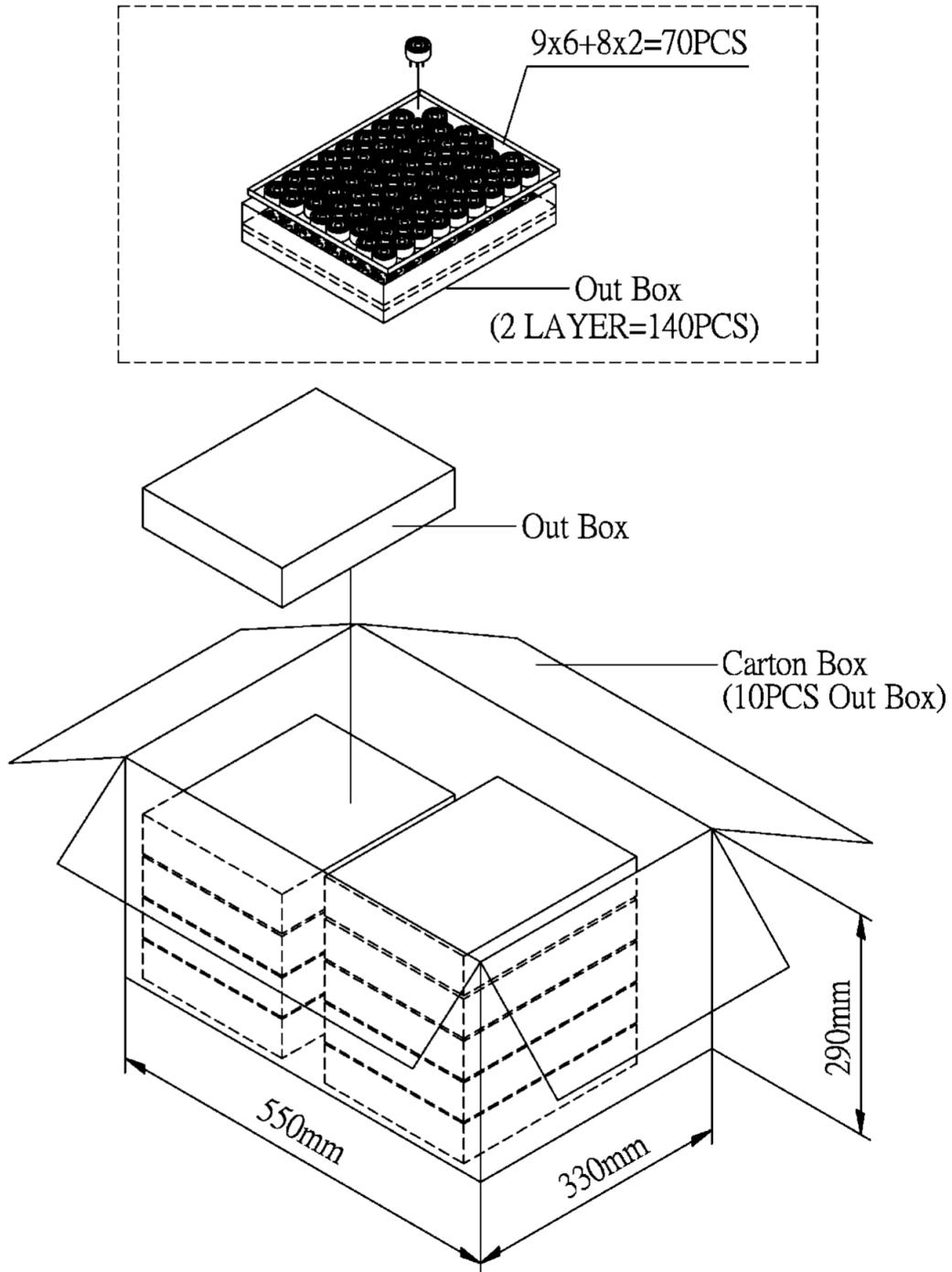
PACKAGING

Out Box	310mmx248mmx49mm	2x70PCS=140PCS
Carton Box	550mmx330mmx290mm	140PCSx10=1,400PCS